



**IES INDOOR REPORT
PHOTOMETRIC FILENAME : LLI080707F.IES**

DESCRIPTION INFORMATION (From Photometric File)

IESNA:LM-63-2002
 [TEST] LLI 0807-07F
 [TESTLAB] LIGHT LABORATORY INC
 [ISSUEDATE] 8/15/2007
 [MANUFAC] KINO FLO, INC.
 [LUMCAT] IMAGE 85 w/ SILVER LOUVER
 [LUMINAIRE] 54"L. X 28"W. X 6.5"H. STUDIO FIXTURE
 [MORE] SPECULAR REFLECTOR
 [MORE] SILVER SQUARE LOUVERS
 [BALLASTCAT] KINOFLO IMAGE 85 DMX
 [BALLAST] 120V 50/60Hz ELECTRONIC
 [LAMPPOSITION] 0,90
 [LAMPCAT] KINO FLO F75/T12/HO/800
 [OTHER] INDICATING THE CANDELA VALUES ARE ABSOLUTE AND
 [MORE] SHOULD NOT BE FACTORED FOR DIFFERENT LAMP RATINGS.
 [_LAMPLUM] 3290
 [_INPUT] 120VAC, 550.8W

CHARACTERISTICS

Total Rated Lamp Lumens	N.A. (absolute photometry)
Total Luminaire Efficiency	N.A.
CIE Type	Direct
Spacing Criteria (0-180)	1.20
Spacing Criteria (90-270)	1.22
Spacing Criteria (Diagonal)	1.20
Basic Luminous Shape	Rectangular
Luminous Length (0-180)	4.00 ft
Luminous Width (90-270)	1.96 ft
Luminous Height	0.00 ft

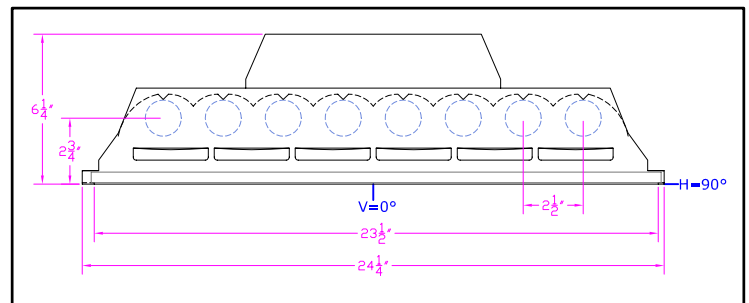

LUMINANCE DATA (cd/sq.m)

Angle In Degrees	Average 0-Deg	Average 45-Deg	Average 90-Deg
45	1946	2931	2227
55	103	179	88
65	71	101	256
75	69	344	514
85	205	1086	1542

**IES INDOOR REPORT
PHOTOMETRIC FILENAME : LLI080707F.IES**

CANDELA TABULATION

	<u>0</u>	<u>22.5</u>	<u>45</u>	<u>67.5</u>	<u>90</u>
0	3905	3905	3905	3905	3905
5	4180	4094	3943	3802	3743
15	3999	3929	3887	3781	3694
25	3505	3493	3488	3483	3408
35	2801	2842	2906	2983	2958
45	1003	1289	1511	1415	1148
55	43	52	75	43	37
65	22	24	31	72	79
75	13	15	65	85	97
85	13	23	69	88	98
90	8	9	12	15	16
95	11	19	50	54	47
105	15	28	47	52	53
115	14	25	47	55	58
125	12	18	40	49	56
135	11	15	31	40	44
145	13	18	27	32	34
155	14	17	23	27	28
165	14	15	18	20	21
175	13	13	13	14	14
180	13	13	13	13	13

IES INDOOR REPORT
PHOTOMETRIC FILENAME : LLI080707F.IES

ZONAL LUMEN SUMMARY

Zone	Lumens	%Lamp	%Fixt
0-30	2211.61	N.A.	34.5
0-40	3959.26	N.A.	61.8
0-60	6023.41	N.A.	94.1
0-90	6201.31	N.A.	96.8
90-120	97.57	N.A.	1.5
90-130	133.62	N.A.	2.1
90-150	179.14	N.A.	2.1
90-180	202.73	N.A.	3.2
0-180	6404.03	N.A.	100

Total Luminaire Efficiency = N.A.%

ZONAL LUMEN SUMMARY

Zone	Lumens
0-10	93.91
10-20	742.77
20-30	1374.94
30-40	1747.65
40-50	1487.29
50-60	576.86
60-70	45.94
70-80	51.14
80-90	80.82
90-100	13.69
100-110	42.2
110-120	41.68
120-130	36.04
130-140	26.69
140-150	18.83
150-160	12.9
160-170	7.42
170-180	3.26

POLAR GRAPH

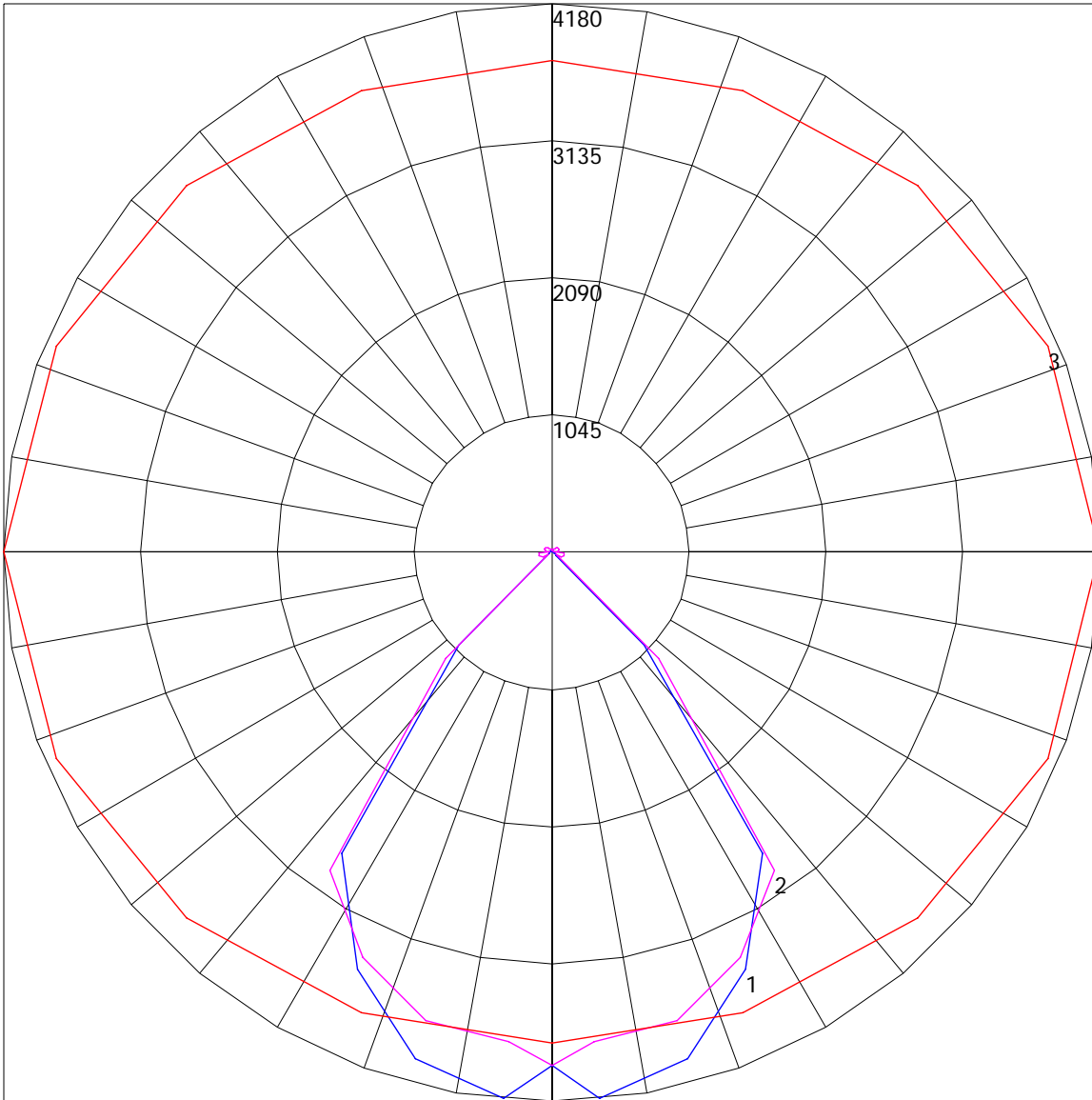

Maximum Candela = 4180 Located At Horizontal Angle = 0, Vertical Angle = 5
1 - Vertical Plane Through Horizontal Angles (0 - 180) (Through Max. Cd.) : BLUE
2 - Vertical Plane Through Horizontal Angles (90 - 270) : MAGENTA
3 - Horizontal Cone Through Vertical Angle (5) (Through Max. Cd.) : RED