

---

# Operation Manual

## MEGA 4Bank DMX



# System

## MEGA 4Bank DMX



**CFX-9604** 8ft 4Bank Fixture  
**CFX-7204** 6ft 4Bank Fixture



**MTP-K81** Mega "Twist-On" Mount  
w/ Junior Pin



**X19-25M** Mega 4Bank  
Extension, 25ft



**BAL-450-M120** Mega 4Bank  
DMX Ballast, 120VAC

**BAL-450-M230** Mega 4Bank  
DMX Ballast, 230VAC

### MEGA 4Bank DMX System consists of:

- 1 Fixture
- 1 Mounting Plate
- 1 Extension Cable
- 1 Mega 4Bank DMX Ballast

# Fixture Assembly

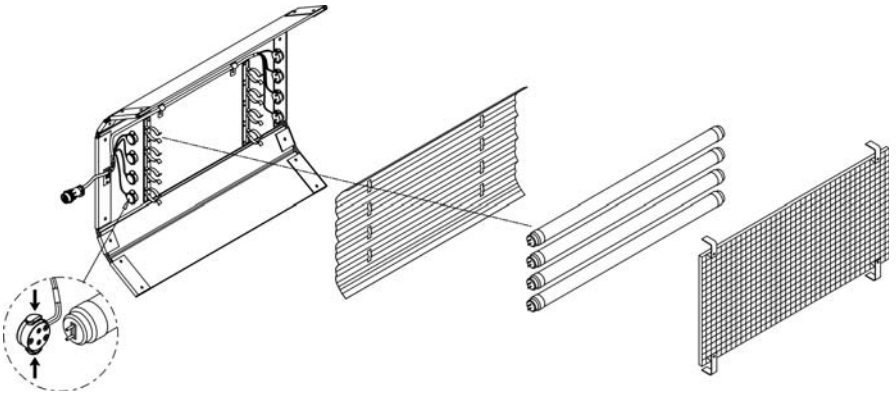

The 4Bank fixture is comprised of a removable Louver, Reflector, and Lamp Harness. The Louver and Reflector are held in place with Velcro fasteners. The Lamp Harness is secured by means of a ¼ turn fastener and two clips.



## To Release the Lamp Harness

Remove the harness from 2 clips located under the reflector. Rotate the ¼ turn fastener clockwise to release harness.



The lamps can operate independent of the fixture allowing them to be built into sets or custom soft boxes or hand held as a single tube for an eye-light.

**WARNING:** Always use safety coated lamps to avoid injury if lamp breaks.

## Lamp Harness Color Codes

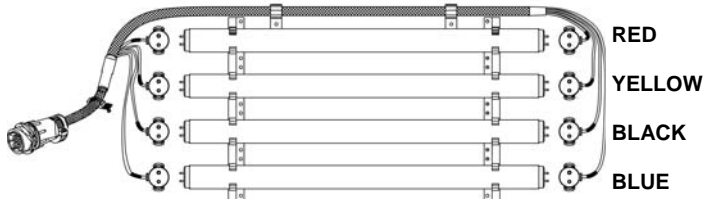

4Bank Harness

The Harness wiring is color-coded. The same color-code must match at each end of the lamp for proper operation.

## Inserting Lamps



### Locking Lamp Connector:

Depress both tabs on lamp connector and apply to lamp pins.  
Match the Harness color-codes at each end of the lamp.  
Push lamps into the fixture's Lamp Holder Clips.

## Gelling the Fixture



Restricting the airflow around the lamps can cause the lamp to operate hotter. This increased heat will raise the lamp's color temperature and green spike. Therefore, it is recommended to clip gels to the Doors of the Fixture.

**Do Not** clip gels to louver.

**Do Not** block the fixture ends in a manner that restricts airflow.

## Mounting the Fixture

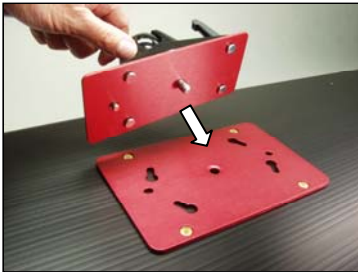

### Mega 4Bank Mounting

Align the center pin of the Mounting Plate (**MTP-K81**) to the center hole on the mating plate. Rotate plate clockwise until the four shoulder rivets drop into the receptacle. A locking pin will snap into place when the plate is properly seated.

The **Silver Loops** provide attachment points for a safety chain.



**To remove the plate**, pull up on the locking pin and reverse the mounting procedure.

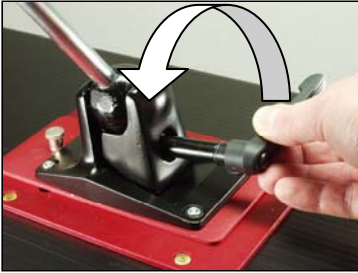

**To loosen or tighten the Lollipop** turn the Lock Lever. The Lever can be adjusted so a 180° turn provides the necessary clamping strength. Reorienting the Lever allows for further tightening or loosening of the clamp.

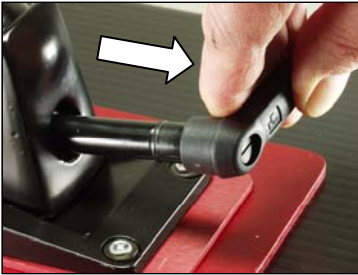

**To reorient the Lock Lever**, pull Lever away from mount. This disengages the Lever from the screw mechanism and allows it to be reoriented.

**Note:** You can also use a screwdriver to adjust the travel. Pull back on Lever and adjust the screw in the center of the Lever.

## Other Fixture Mounting Options



The grommet holes along the edge of the fixture are designed to allow the fixture to be screwed onto set walls.



# Extension Cable



To insert the cable, align the key ways on the extension cable with the circular receptacle on the ballast. Rotate the locking ring until it clicks into the lock position.

Lamps can operate as far as 75 feet from the ballast. (3 x 25ft extensions)



A **Splitter** can be used at the Ballast or on the end of an Extension Cable to split a 4Bank run into either 4 Singles or 2 Doubles. This allows for greater rigging flexibility.



A **Combiner** can connect a number of smaller ballasts to a larger fixture. For example, 4 Single Ballasts or two Double Ballasts can be combined to a 4Bank Extension or Fixture.

# Ballast Operation

## WARNING!

- 1) ALWAYS TURN OFF THE BALLAST BEFORE connecting or disconnecting Lamps, Harnesses or Extension Cables.
- 2) Use only with Sine wave inverters. Do not operate on SCR dimmers.
- 3) If powering the ballasts through a Dimmer Pack set the Dimmer to Non-Dim Mode.

The 120 VAC Ballast requires 110 to 130 Volts AC 50/60 Hertz on an earth grounded circuit; the 230 VAC Ballast requires 220 to 240 Volts AC on an earth grounded circuit. The electronic Ballast operates at a high frequency of 25 KHz. It is dead-quiet, instant-on and lightweight.



## Ballast Operation Continued....

### Load Considerations:

Kino Flo ballasts are not power factor corrected. They will draw double the current on the neutral from what is being drawn on the two hot legs.

On large installations it may be necessary to double your neutral run so as not to exceed your cable capacity.

### Cold Temperature Operation

The Select Ballast series is designed to operate at temperatures from 14F to 122F (-10C to +50C). In cold temperatures, the Ballast may not strike the lamp(s) instantly. Switch the Ballast to OFF, wait seven seconds and try again. If the Ballast does not strike after two or three attempts, turn off the Ballast, check that the Extension and Harness connections are secure and re-strike. Once operating for a few minutes, the Lamps should re-strike instantly.

# Manual Operation

The Ballast operates remote from the fixture. Connect the Extension cable to the Ballast and the Lamp Harness. After the lamps are properly installed the Ballast can be turned on. Each switch controls one lamp. The color bands on the lamp harness correspond to the switches as illustrated.

### Color Band

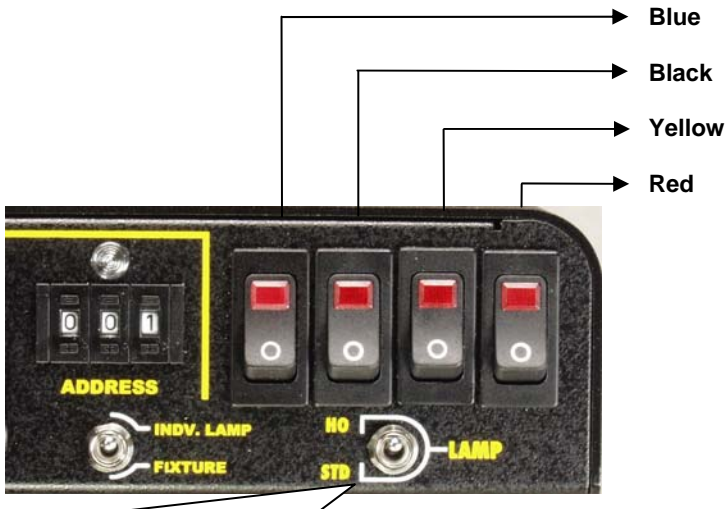

### Lamp Select Feature

The Select Ballasts have a **HO / STD** switch. Set the Selector Switch to **HO** for High Output and **STD** for Standard Light Output.



### Lamp Select feature continued...

When operating 8 or 6ft lamps in high ambient temperature or where the units are rigged into place with restricted airflow, the **STD** setting can be used to lower the color temperature and remove any green spike. The light drops about a half an f-stop in exposure when dropping from **HO** to **STD**.

## Mega 4Bank DMX Control Panel

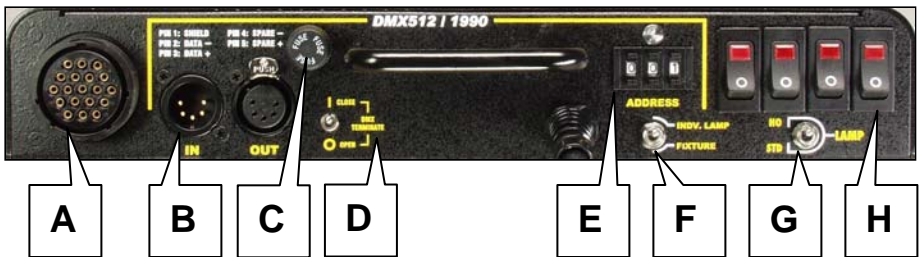

- A) **Circular Output Connector:** Provides electrical power to the lamp head with the use of a 4Bank extension cable.
- B) **DMX-In & DMX-Out:** DMX-IN receives DMX signals from Dimmer Board. DMX-OUT relays DMX signal through to other Fixtures or Instruments.
- C) **Fuse:** Provides circuit protection. *Note: If Fuse is "blown" or "open" replace with same type of fuse rating as marked.*
- D) **DMX TERMINATE Switch:** Terminates DMX signal at the end of Fixture series.
- E) **DMX Address:** Sets DMX Address of Fixture.
- F) **Individual Lamp / Fixture Switch:** Converts between INDIVIDUAL LAMP and FIXTURE methods of DMX control.
- G) **Lamp Select:** Set to **HO** for burning lamps at high output and **STD** for burning lamps at Standard Light Output.
- H) **Manual Switches:** Turns lamps on and off manually.

# DMX Operation



## IMPORTANT!

The dimmer board/light console should have its channel set to LINEAR light output response. (LINEAR response is the default setting on most dimmer boards.)

## DMX Addressing

Push the tabs above or below the number window to set the address.

(Valid addresses range from 001 to 512.)

The yellow light above the address block will illuminate if a DMX signal is present.

## Each Mega 4Bank DMX ballast operates on 5 addresses.

After the DMX address is entered, the ballast automatically assigns the next 4 addresses to lamps 2,3,4 and a 5<sup>th</sup> address controls the **STD** setting. Programming the 5<sup>th</sup> address at full dimmer setting activates the **STD** setting.

**Note:** When DMX cables are applied the manual **HO/STD** select feature will be disabled. To get manual control of the **HO/STD** feature 1)Unplug the DMX cable or 2) leave cables plugged in and set address to "000". There is a 5 second delay when switching between DMX and Manual control.

**Manual lamp switching is not affected by DMX control.**



The **DMX Terminate Switch** must be set to open ( **O** ) on Ballasts within the DMX chain.

Set to closed ( **I** ) when the Ballast is the last DMX control device in the chain.

*Note: When the last Ballast's DMX Terminate Switch is set to "I," it will absorb all energy in the DMX line, ensuring DMX signals are transmitted correctly. If a signal is not terminated, it is called a "Reflected Wave," and may create transmission errors by causing valid DMX signals to be canceled.*



Any theatrical lighting board with DMX 512 protocol can be used to individually turn **on/off** lamps in a Fixture.

Mega DMX 4Bank Ballasts can be jumpered using the IN and OUT ports. As many as 100 Ballasts can be jumpered on one chain as long as the DMX cable run remains under 1000 feet or 40 x 25ft DMX cables.

**Note:** When operating Ballasts at great distances from the dimmer board, it is recommended to use Opto-Isolators to provide DMX signal amplification.



### DMX Cables

The Fixture uses five-pin XLR male and female connectors to receive DMX signals from the Dimmer Board and jumper the Fixtures in a series. DMX pin-out wiring follows the USITT DMX512 standard:

- Pin 1: Shield**
- Pin 2: Data -**
- Pin 3: Data +**
- Pin 4: Spare -**
- Pin 5: Spare +**

*Note: Pin four and five in the Fixture are connected internally as Pin four to four and Pin five to five. Connecting Pin four and five as the pass-thru allows secondary data to be passed through for other equipment.*

**Do Not use Microphone Cables** and other general purpose, two-core Cables designed for audio or signaling use. They are not suitable for DMX 512.

Problems due to incorrect cabling may not be immediately apparent. Microphone Cables may appear to work fine, but systems built with such Cables may *fail* or be prone to *random errors*. Cable must comply with EIA-485 (RS485).

**NOTE: If a Fixture or Ballast loses its DMX signal it will hold its last DMX command.** For this reason it is important to turn a Fixture or Ballast off using the DMX commands. For example, if you try to turn off the lights by turning off the dimmer board the lights will remember their last DMX command and stay on. The Fixtures or Ballasts require a DMX "Off" or "Black-out" command in order to turn off.

# Fixture Mode

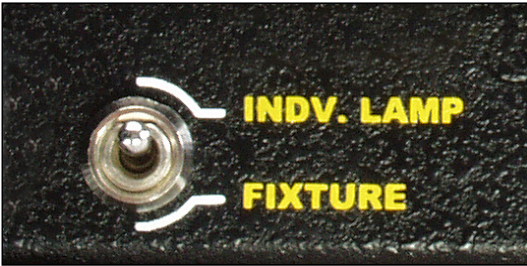

Setting the unit to "Fixture Mode" allows the user to turn lamps on and off with an "inside-out" pattern from a dimmer board.

One of the best applications for the "Fixture Mode" is when lighting Blue and Green Screens or large Cycloramas.

For example: One row of fixtures can be set to Fixture mode on a common address. When the fader on the dimmer board is brought up or down all the Fixtures on that address will have the same lamps turned on.

## Dimmer level - Lamp response

Each ballast has 5 addresses. Addresses 001-004 control the lamps. Sliding the fader on the dimmer board from 0 ~ 100 controls the number of lamps that are on within a fixture. Address 005 controls the **STD** setting.

**Note:** The lamps may respond  $\pm 4$  channel levels, depending on the dimmer board. To control the **STD** select feature, program the 5<sup>th</sup> address (005) at full. Setting the dimmer value under 49% or not programming address 5 will restore the **HO** setting.

## 4Bank Lamp Sequence

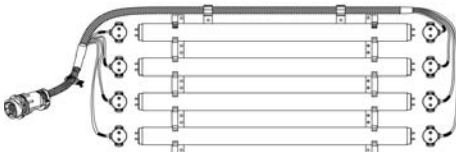

4 ( Red )  
 2 ( Yellow )  
 1 ( Black )  
 3 ( Blue )

## DMX Lamp Sequence

Lamp #	Dimmer Level
Lamp 1	12
Lamp 1~2	37
Lamp 1~3	64
Lamp 1~4	83

## To Control Light Levels from Multiple Fixtures:

- 1) Set ballast to **Fixture** mode.
- 2) Set all ballast addresses to a common address (eg. 001).
- 3) Set address 005 if the **STD** setting is required.
- 4) Set end of line switch to "I" on the last unit in the DMX chain.

# Individual Lamp Mode

Setting the unit to “Individual Lamp” mode allows each lamp within the fixture to have its own address. Although this option will use up a lot of addresses, it may be preferable for certain situations.

The “Individual Lamp” mode is useful in achieving light effects like flickering, chasing or creating light patterns. Individual lamps or fixtures can be rigged into a set by using a 4Bank to Single or Double splitter. A Single splitter can provide 4 individual cable feeds to lamps or fixtures in a set. (For parts see page 16)

After the DMX address is entered, the Mega 4Bank DMX ballast automatically assigns the next 4 addresses to lamps 2, 3, 4 and the 5<sup>th</sup> address controls the **STD** setting. On address 5, to activate the **STD** lamp setting, set dimmer slider to full. Setting the dimmer value under 49% or not programming address 5 will restore the **HO** setting.

Note: The **HO/STD** select setting controls all 4 lamps equally. Individual settings per lamp are not possible.

For example, if the 4Bank DMX base address is set at 001, the configuration below will provide 4 lamps individually addressable through DMX 512.

## 4Bank Lamp Sequence

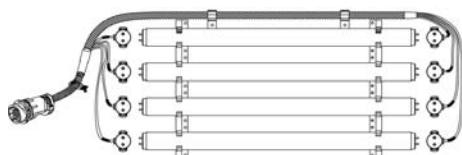

4 ( Red )  
2 ( Yellow )  
1 ( Black )  
3 ( Blue )

DMX Address Sequence DMX address 001	
Lamp#	DMX Address
Lamp 1	1
Lamp 2	2
Lamp 3	3
Lamp 4	4
<b>STD Setting</b>	5

**To Chase one lamp through multiple fixtures:**

- 1) Set ballast to **Individual Lamp** mode.
- 2) Set each ballast with its own address: 001, 006, 011, 016 and so on.
- 3) Program lamp sequence to chase from 001 through 004, 006-009, 011-014 and so on. (note: skipping the **HO/STD** function)
- 4) Set end of line switch to "I" on the last unit in the DMX chain.

**To Chase same lamp position simultaneously through multiple fixtures:**

- 1) Set ballast to **Individual Lamp** mode.
- 2) Set each ballast address to 001 ( or a common address ).
- 3) Program lamps to chase from address 001-004.
- 4) Set end of line switch to "I" on the last unit in the DMX chain.

## System Components



**CFX-9604** 8ft Mega 4Bank Fixture  
**CFX-7204** 6ft Mega 4Bank Fixture



**MTP-K81** Mega "Twist-On" Mount  
w/Junior Pin



**X19-25M** Mega 4Bank Ext. Cable, 25ft



**BAL-450-M120** Mega 4Bank  
DMX Ballast, 120VAC  
**BAL-450-M230** Mega 4Bank  
DMX Ballast, 230VAC

## Accessories and Parts



**FIX-9604** 8ft Mega 4Bank Fixture Shell  
**FIX-7204** 6ft Mega 4Bank Fixture Shell



**HAR-9604** 8ft Mega 4Bank Harness  
**HAR-7204** 6ft Mega 4Bank Harness

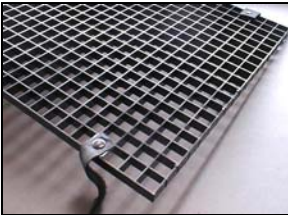

*8ft Fixtures require two 4ft Louvers*  
**LVR-4804-B** 4ft 4Bank Louver, Black

*6ft Fixtures require two 3ft Louvers*  
**LVR-3604-B** 3ft 4Bank Louver, Black





**MTP-BAL** Select Ballast Mount



**MTP-LM** Mega Lollipop w/Junior Pin



**MTP-LMT** Mega Lollipop Straight w/  
Junior Pin



**REF-9604** 8ft Mega 4Bank Reflector  
**REF-7204** 6ft Mega 4Bank Reflector



**X19-A7M** Mega 4Bank to Mega Single  
Splitter  
**X19-A9M** Mega 4Bank to Mega Double  
Splitter

# Expendables



**EXP-LHC-T12** Lamp Holder Clips T12,  
24pk



**EXP-M&T** Adhesive Mounts and  
Releasable Ties, 25pk



**PRT-HLC** Kino Locking Lamp Connector,  
1 pk

See web site: [www.kinoflo.com](http://www.kinoflo.com) for more repair parts

# Cases



KAS-96



KAS-96L



KAS-KFC

Part Number	Description	Dimensions	Weight (Empty)	Holds
INS-L4	4-Lamp Foam Pad	24 x 9 x 1" (61 x 23 x 2.5cm)	N/A	Fits KAS-48, 72, 96
INS-L6	6-Lamp Foam Pad	24 x 13 x 1" (61 x 33 x 2.5cm)	N/A	Fits KAS-54S, 54L, 96L
KAS-72	6ft Lamp Ship Case	71 x 10.5 x 11" (180.5 x 26.5 x 28cm)	20lb / 9kg	6ft Lamps (20)
KAS-96	8ft Lamp Ship Case	100.5 x 11 x 12.5" (255.5 x 28 x 32cm)	28lb / 12.6kg	8ft Lamps (24)
KAS-96L	8ft Fixture Ship Case	100.5 x 14.5 x 16" (255.5 x 37 x 40.5cm)	38lb / 17.1kg	8ft Mega 4Bank Fixture (5)
KAS-KFC	Ballast & Cable Crate w/ Lid	21.5 x 15 x 12" (54.5 x 38 x 30.5cm)	6lb / 2.7kg	Ballasts, Cables, Mounting Plates

# Fixture Specifications

## Kino Flo Mega 4Bank Fixture Dimensions

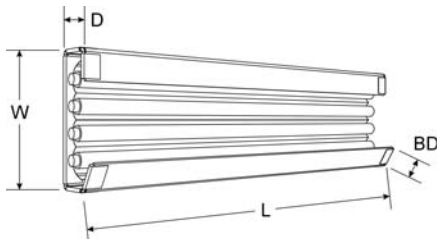

Fixture Style	Length	Width	Depth	Barndoor Width	Weight w/Lamps
8ft Mega 4Bank	97"	13"	3.5"	3.5"	21.8 lbs
6ft Mega 4Bank	73.5"	13"	3.5"	3.5"	18.5 lbs

# Lamp w/Harness Specifications

## Kino Flo Lamp w/ Harness Dimensions

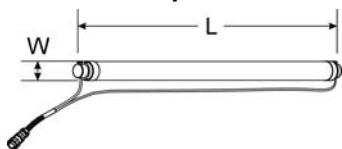

Lamp Type	Length	Width
8ft Med. Bi-Pin	94.5"	1.5"
6ft Med. Bi-Pin	70.5"	1.5"

# Ballast Specifications



### BAL-450-M120

Mega 4Bank Dmx Ballast, 120VAC

Input Voltage: 120VAC 50/60Hz  
 Output Frequency: 25 kHz  
 Amperage: F120 / 7.1A, F100 / 5.8A  
 Lamp switching: 4-1/off  
 Output Switching: HO / STD  
 Ballast size: 13 x 12.5 x 2.5"  
 (33 x 32 x 6.5cm)  
 Weight: 6.5lb / 2.9kg

### BAL-450-M230

Mega 4Bank Dmx Ballast, 120VAC

Input Voltage: 230VAC 50/60Hz  
 Output Frequency: 25 kHz  
 Amperage: F120 / 3.7A, F100 / 2.8A  
 Lamp switching: 4-1/off  
 Output Switching: HO / STD  
 Ballast size: 13 x 12.5 x 2.5"  
 (33 x 32 x 6.5cm)  
 Weight: 6.8lb / 3.1kg

## **Environmental: Disposal of Old Electrical & Electronic Equipment.**



This symbol on the product or on its packaging indicates that this product shall not be treated as household waste. This product is made of recyclable materials and should be disposed of in accordance with local and state regulations.

---

Kino Flo, Inc. 2840 N. Hollywood Way, Burbank, CA 91505, USA  
Tel: 818 767-6528 website: [www.kinoflo.com](http://www.kinoflo.com)